

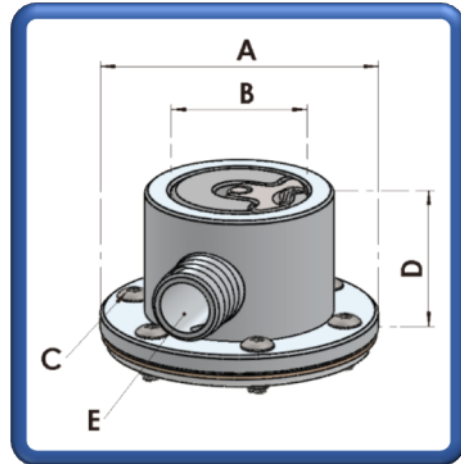

Quick-Fill

**Aero 200 Filler Cap, Non-Vented, Non-Locking, Silver,
Ø1" Air-Return Hose Spigot.
Part Number: OA-ZA-017 (QFT250TF)**



Specifications:

Fixing Arrangement:

Applications:

Compatibilities:

Finish:

Weight:

Supplied With:

6 x M05 CSK Bolts

Sports Car/ Motorcycle Racing & Endurance

Operation Temperature -40°C to +80°C

Anodised

700.0 grams

M05 Bolt Button Screws

Fixing Rings C-Style

NBR Cork Gasket

Materials:

Flange:

Seal plate:

O-Ring:

Springs:

Gasket:

Lever & Centre Pin:

Saddle:

Aluminium 6082/T6 Machined

Aluminium 6036/T1 Forged

Viton

Stainless Steel EN43

Neoprene Bonded Cork (NBR)

Stainless Steel 304

Acetal POM Plastic CS2125L

Dimensions:

Outer Diameter A:

Centre Cap Diameter B:

Bolt PCD Diameter C:

Depth D:

Spigot Hose Diameter:

Flange Thickness:

94.0mm

46.0mm

64.0mm

55.0mm

Ø25.4mm (1")

7.0mm

Associated Parts:

Locking Cap

Viton Gasket

Lanyard

Fluid Containment – When It Matters

Tell: +4420 8594 7990 / Fax: +4420 8594 7989 / www.newton-equipment.com / info@newton-equipment.com

Registered in England. 6 Orwell Close/ Fairview Ind. Park/ Rainham/ Essex/ RM13 8UB