

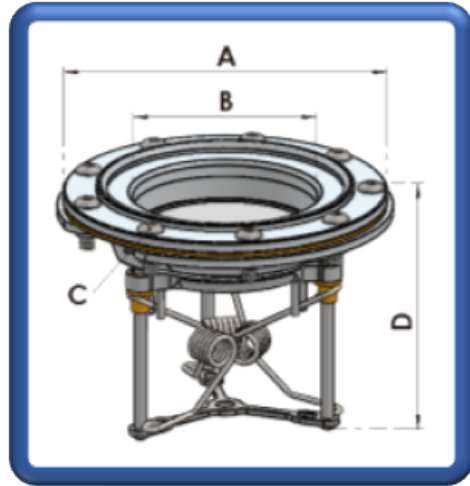

# Quick-Fill

**Female 2", Single Mount, Silver.**  
**Part Number: RF-AA-001 (QFT251)**



## **Specifications:**

**Fixing Arrangement:**

**Applications:**

**Compatibilities:**

**Finish:**

**Weight:**

**Supplied With:**

9 x M05 CSK Bolts

Sports Car/ Motorcycle Racing & Endurance

Operation Temperature -40°C to +80°C

Anodised

350.0 grams

M05 Bolt Button Screws

NBR Cork Gasket

## **Materials:**

**Flange:**

**Seal plate:**

**O-Ring:**

**Springs:**

**Gasket:**

**Spindle Pins & Spider:**

**Bushes:**

Aluminium 6082/T6 Machined

Aluminium 6082/T6 Machined

NBR

Stainless Steel EN43

Neoprene Bonded Cork (NBR)

Stainless Steel 304

Brass CZ114

## **Dimensions:**

**Outside Diameter A:**

**Internal Diameter B:**

**Bolts Circle Diameter C:**

**Depth D:**

**Spigot Diameter:**

**Flange Thickness:**

112.0mm

61.1mm

88.9mm

99.0mm

Ø86.0mm (87.0mm Cut-Out)

4.0mm

## **Associated Parts:**

Quick-Fill Male

***Fluid Containment – When It Matters***

Tell: +4420 8594 7990 / Fax: +4420 8594 7989 / [www.newton-equipment.com](http://www.newton-equipment.com) / [info@newton-equipment.com](mailto:info@newton-equipment.com)

Registered in England. 6 Orwell Close/ Fairview Ind. Park/ Rainham/ Essex/ RM13 8UB