

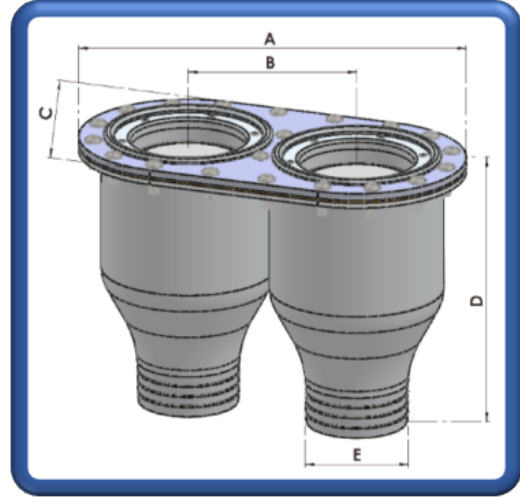

Quick-Fill

Female 2", Dual Remote Mount, Silver. Part Number: RF-AA-004 (QFR252)



Specifications:

Fixing Arrangement:

Applications:

Compatibilities:

Finish:

Weight:

Supplied With:

20 x M05 CSK Bolts

Sports Car/ Motorcycle Racing & Endurance

Operation Temperature -40°C to +80°C

Anodised

700.0 grams

M05 Bolt Button Screws

NBR Cork Gasket

Materials:

Flange:

Seal plate:

O-Ring:

Springs:

Gasket:

Spindle Pins & Spider:

Bushes:

Aluminium 6082/T6 Machined

Aluminium 6082/T6 Machined

NBR

Stainless Steel EN43

Neoprene Bonded Cork (NBR)

Stainless Steel 304

Brass CZ114

Dimensions:

Length A:

Centre to Centre B:

Width C:

Depth D:

Spigot Hose Diameter:

Flange Thickness:

222.0mm

100.0mm

122.0mm

99.0mm

Ø51.0mm

4.0mm

Associated Parts:

Quick-Fill Twin & Single Male

Fluid Containment – When It Matters

Tell: +4420 8594 7990 / Fax: +4420 8594 7989 / www.newton-equipment.com / info@newton-equipment.com

Registered in England. 6 Orwell Close/ Fairview Ind. Park/ Rainham/ Essex/ RM13 8UB